

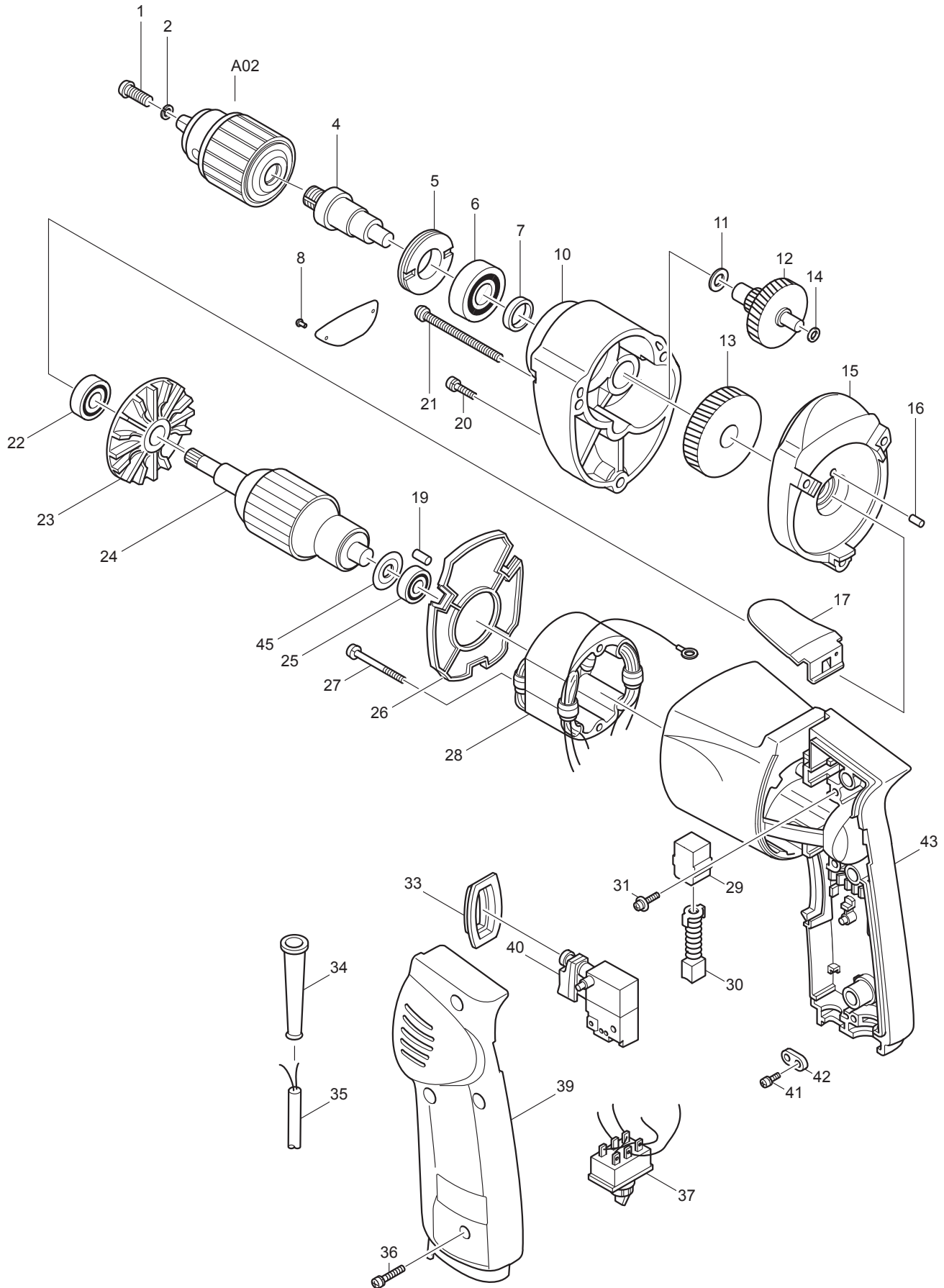

12 - 2010  
6510LVR / 6510LVRK  
3/8" DRILL



Item No	Type	Sub	Part No	Description	Qty	Unit
001		3	251448-1	- PAN HEAD SCREW M5X18	1	PC.
004			323685-8	SPINDLE	1	PC.
005			285804-3	BEARING RETAINER 19-34	1	PC.
006			211201-7	BALL BEARING 6002LLB	1	PC.
007			257053-2	RING 15	1	PC.
009			869485-7	NAME PLATE 6510LVR	1	PC.
010			156401-1	GEAR HOUSING	1	PC.
		INC.	214001-4	PLANE BEARING 8	1	PC.
011			253139-0	FLAT WASHER 8	1	PC.
012			226032-1	GEAR COMPLETE 13-40	1	PC.
013			221624-1	HELICAL GEAR 53	1	PC.
014			253077-6	FLAT WASHER 6	1	PC.
015			156402-9	GEAR HOUSING COVER	1	PC.
		INC.	214001-4	PLANE BEARING 8	1	PC.
		INC.	214004-8	PLANE BEARING 6	1	PC.
		INC.		Item No. 16		
016			263002-9	RUBBER PIN 4	1	PC.
017			343693-3	HOOK	1	PC.
019			263002-9	RUBBER PIN 4	1	PC.
020			911168-6	PAN HEAD SCREW M4X40	1	PC.
021			911188-0	PAN HEAD SCREW M4X60	2	PC.
022			211033-2	BALL BEARING 608LB	1	PC.
023			241802-7	FAN 58	1	PC.
024		3	511795-5	ARMATURE ASS'Y 100V-115V	1	PC.
		INC.		Item No. 22,23,25,45		
025			211028-5	BALL BEARING 627LB	1	PC.
026			414292-9	BAFFLE PLATE	1	PC.
027			911571-1	PAN HEAD SCREW M4X45	2	PC.
028			533081-4	FIELD 115V	1	PC.
029			643552-4	BRUSH HOLDER 5-8	2	PC.
030		2	194971-2	CARBON BRUSH CB-75 2PC/SET (W/ ORIGIN)	1	SET
031			911124-6	PAN HEAD SCREW M4X14	2	PC.
032			931102-0	HEX NUT M4	3	PC.
033			421144-7	DUST COVER	1	PC.
034			682559-5	CORD GUARD 8	1	PC.
035			664064-4	CORD W/PLUG 2P-18-2.5M, SJ	1	PC.
036			911153-9	PAN HEAD SCREW M4X28	3	PC.
037			651475-2	SWITCH 8928K370	1	PC.
039			154967-5	HANDLE COVER COMPLETE	1	PC.
		INC.	817613-8	CAUTION LABEL	1	PC.
		INC.	816266-0	INDICATION LABEL	1	PC.
040			650208-2	SWITCH TG833TB-1	1	PC.
041			911133-5	PAN HEAD SCREW M4X18	2	PC.
042			687002-9	STRAIN RELIEF	1	PC.
043			188104-9	MOTOR HOUSING SET	1	PC.
		INC.	819063-3	MAKITA LABEL	1	PC.
		INC.		Item No. 19		
		INC.	816266-0	INDICATION LABEL	1	PC.
045			681617-4	INSULATION WASHER	1	PC.
050			411780-7	KEY HOLDER 10	1	PC.

Item No	Type	Sub	Part No	Description	Qty	Unit
<b><u>ACCESSORIES</u></b>						
A01	2		763403-6C	CHUCK KEY S10	1	PC.
A02			763136-3	DRILL CHUCK S10	1	PC.
A03	2		824700-6	PLASTIC CARRYING CASE	1	PC.
		INC.	417496-2	LATCH	2	PC.
		INC.	417497-0	HANDLE	1	PC.
		INC.	819143-5	MAKITA LABEL	1	PC.

**SERVICE CHANGES**

**1. Changes on Drill Chuck, Chuck Key, Spindle, etc.**

Item No.	Description	Type 1	Type 2	Type 3	Type 4	
1	Screw	251266-7 (+) PH M5X35 (N.L.A.)	251277-2 (+) PH M5X18 (N.L.A.)	251488-1 (-) PH M5X18		
		Type 5	Type 6	Type 7	Type 8	
		251488-1 (-) PH M5X18				
2	Spring Washer 5	Type 1	Type 2	Type 3	Type 4	
		-----	942101-7 (Added)			
		Type 5	Type 6	Type 7	Type 8	
		942101-7 (Added)				
4	Spindle	Type 1	Type 2	Type 3	Type 4	
		323663-8 (N.L.A.)	323685-8			
		Type 5	Type 6	Type 7	Type 8	
		323685-8				
A01	Chuck Key	Type 1	Type 2	Type 3	Type 4	
		763403-6			763403-6A	763403-6B (N.L.A.)
		Type 5	Type 6	Type 7	Type 8	
		763403-6C	763424-8	763433-7 (N.L.A.)	763403-6C	
A02	Drill Chuck	Type 1	Type 2	Type 3	Type 4	
		763045-6 (N.L.A.)	763048-0 (N.L.A.)	763048-0A	763048-0B (N.L.A.)	
		Type 5	Type 6	Type 7	Type 8	
		763048-0C	763104-6	763074-9 (N.L.A.)	763136-3	

Above parts are completely interchangeable as a set.

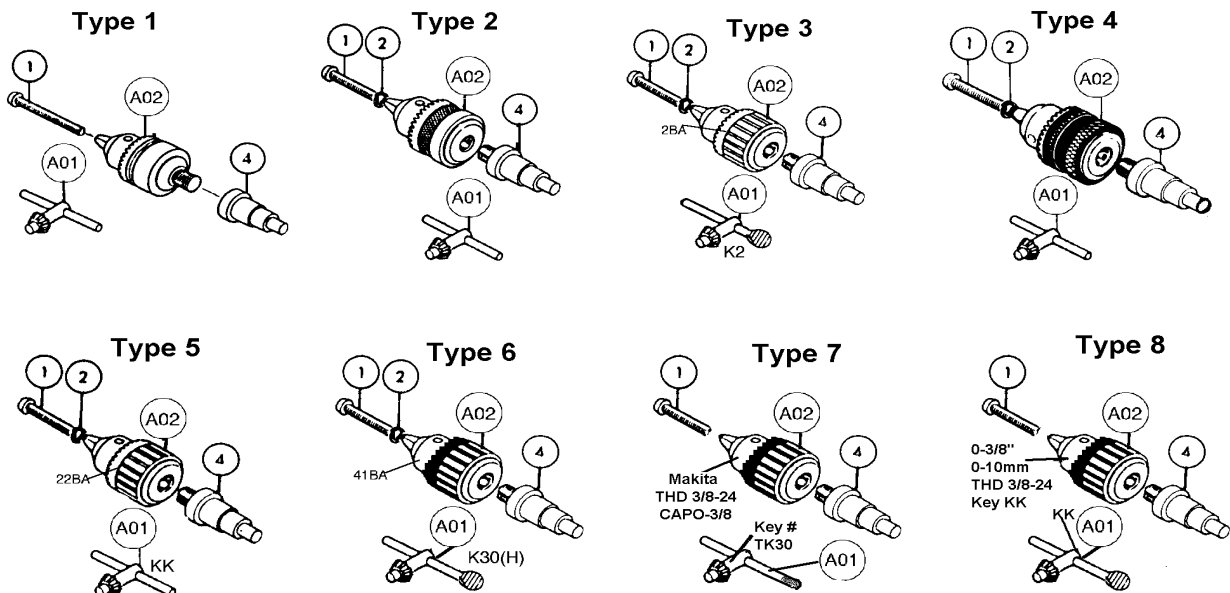

**2. Changes on Motor Housing Set and Handle Cover Com.**

**SERVICE CHANGES**

Item No.	Description	Type 1	Type 2	Type 3	Type 4
43	MOTOR HSG COM.	411215-8 (N/L/A)	411411-8 (N/L/A)	156491-4 (N/L/A)	
		Type 5	Type 6	Type 7	Type 8
		159089-6 (159423-0) (N/L/A)			188104-9
Item No.	Description	Type 1	Type 2	Type 3	Type 4
39	HANDLE COVER	411216-6 (N/L/A)	155216-3 (N/L/A)	155300-4 (N/L/A)	
		Type 5	Type 6	Type 7	Type 8
		155300-4A	155300-4B		154967-5

Above parts are completely interchangeable as a set.